

Review

Hybrid Synthetic and Natural Fibres in Honeycomb Sandwich Composite Structures for Structural Applications: A Brief Review

M. R. M. Asyraf^{1, 2, *}, M. Y. Yahya², S. A. Hassan², R. A. Ilyas², D. D. C. V. Sheng³, N. N. Mas'ood³, W. A. A. Saad³, A. H. M. Yusop³, and M. Rafidah⁴

¹ Engineering Design Research Group (EDRG), Faculty of Mechanical Engineering, Universiti Teknologi Malaysia (UTM), Johor Bahru 81310, Johor, Malaysia.

² Centre for Advanced Composite Materials (CACM), Universiti Teknologi Malaysia (UTM), Johor Bahru 81310, Johor, Malaysia.

³ Faculty of Mechanical Engineering, Universiti Teknologi Malaysia (UTM), Johor Bahru 81310, Johor, Malaysia.

⁴ Department of Civil Engineering, Faculty of Engineering, Universiti Putra Malaysia (UPM), UPM Serdang 43400, Selangor.

* Correspondence: muhammadasyraf.mr@utm.my (M.R.M.A.)

Abstract: Lately, natural fibres reinforced composites are noticeably employed in various applications due to their lightweight, renewability, cheap in price, high strength-to-weight ratio, lower density, and energy requirements for processing. But aside from its advantages, natural fibres were lacks in term their applications, especially in certain environment and load requirement. To resolve the problem in load requirement, hybridization has gained huge consideration by researchers. The hybridization between natural fibre with synthetic-based materials can be formed into a sandwich structure to reduce the water absorption and provide optimal mechanical durability. On one hand, sandwich structure applications were exploited in various industrial sectors since they are excellence at absorbing energy aside from very lightweight, greater strength and stiffness-to-weight ratios. Yet, the application of hybrid natural/synthetic fibre composite in sandwich structure is still limited in structural sector. Thus, this paper reviews the potential use of hybrid natural/synthetic fibre material in a sandwich structure application. This article aids the researchers to provide a good source of literature for doing further research on this topic to consider them construction and building materials in term of crashworthiness and energy absorbing views.

Keywords: core structure; honeycomb; mechanical properties; natural fibre; polymer composites; sandwich structure.

1. Introduction

A sandwich structure consists of a core affixed to two distinct layers. Sandwich composite structures utilize stiff and robust coverings, and the core distributes load between the skins. The adhesive that transfers shear and axial stresses to the core material is used as a bonding agent [1]. Rarely, the skin (or sometimes referred to as the face layer) weighs a few milligrams and is composed of lightweight alloys. These lightweight alloys include aluminium, a single metallic layer, and laminated or fibre-reinforced composites. Sandwich structures typically employ core designs such as honeycomb, lattice, truss, or web-reinforced options and cellular. Choosing sandwich materials primarily depends on a number of factors, such as the structure's function [2], lifetime loading [3], the value and price of the materials [4], [5]. Carbon epoxy and graphite epoxy with multilayered facings

Citation: Asyraf, M.R.M.; Yahya, M.Y.; Hassan, S. H. *et al.* Hybrid Synthetic and Natural Fibres in Honeycomb Sandwich Composite Structures for Structural Applications: A Brief Review. *Journal of Natural Fibre Polymer Composites (JNFPC)* 2023, 2(1), 5.

Academic Editor: M.N.F. Norrahim

Received: 13th March 2023

Accepted: 14th May 2023

Published: 30th June 2023

are utilized for aerospace applications. For the facings of civil, marine, and domestic products, however, glass epoxy or glass vinyl ester is used [6], [7].

Gay et al. [8] state aeronautical constructions employ aluminium or Nomex honeycomb cores. Birman & Kardomateas [9] recommended closed-cell or open-cell foam for civil engineering and balsa for ship sandwich constructions. Hence, impact mechanics and high-energy absorption materials created a competitive structure in aircraft, transportation, marine, and civil constructions, where high strength, low weight, and fuel economy are crucial. Carruthers et al. [10] presented a detailed energy-absorbing and crash-worthiness study. This review has demonstrated that fibre reinforced plastics can be designed to exhibit higher normalized energy absorption capabilities than the metals which have been traditionally used for vehicle construction. This review shows that fibre reinforced plastics may be developed to have higher normalized energy absorption than vehicle-building metals. Alghamdi [11] examined collapsible energy absorbers in circular tubes, square tubes, frusta, struts, honeycombs, and sandwich plates. Qiao et al., [12] studied impact mechanics and high energy-absorbing structures and materials, as well as innovative designs for lattice structures with high energy absorption. Chai & Zhu [13] reviewed the low-velocity impact of sandwich structures. Tarlochan et al. [14] investigated quasi-static compression of composite sandwich constructions with tubular inserts. As noted by Zuhri et al., [15], sandwich structures can be seen in natural fibre structures, such as bamboo and grass.

Due to its low cost, lightweight, high strength-to-weight ratio, renewability, reduced density, and lower energy needs for manufacturing, honeycomb sandwich composites are widely employed in a variety of applications. Nevertheless, natural fibres have inherent limitations that limit their usage, such as particular environmental and load requirements. Treatment of fibres and hybridization have received a lot of attention from researchers to solve the issue of load demand and enhance the inferior mechanical characteristics associated with natural fibres. The researchers may use these two strategies to create a sandwich construction with minimal water absorption and maximum mechanical performance. The possible usage of natural fibre material in a sandwich construction application is thoroughly investigated in this paper. This study will concentrate on current research on sandwich structure materials and the feasibility of employing natural fibre composites in sandwich structure applications. In addition, the mechanical performance of cellular foams, corrugated cores, and honeycomb cores under quasi-static and dynamic compression loadings will be studied. Furthermore, this review examines how a sandwich construction formed of natural fibre composite might offer superior performance, such as their energy-absorbing property. The essay will discuss many types of hybrid sandwich structures, their performance, limits, and potential areas for development to meet a wider variety of applications.

2. Natural fibre

Natural fibres were categorised into three classes depending on their origins, which include mineral, plant, and animal sources. Figure 1 shows the example of natural fibre from various sources such animal and plant-based by-product which are available in market.

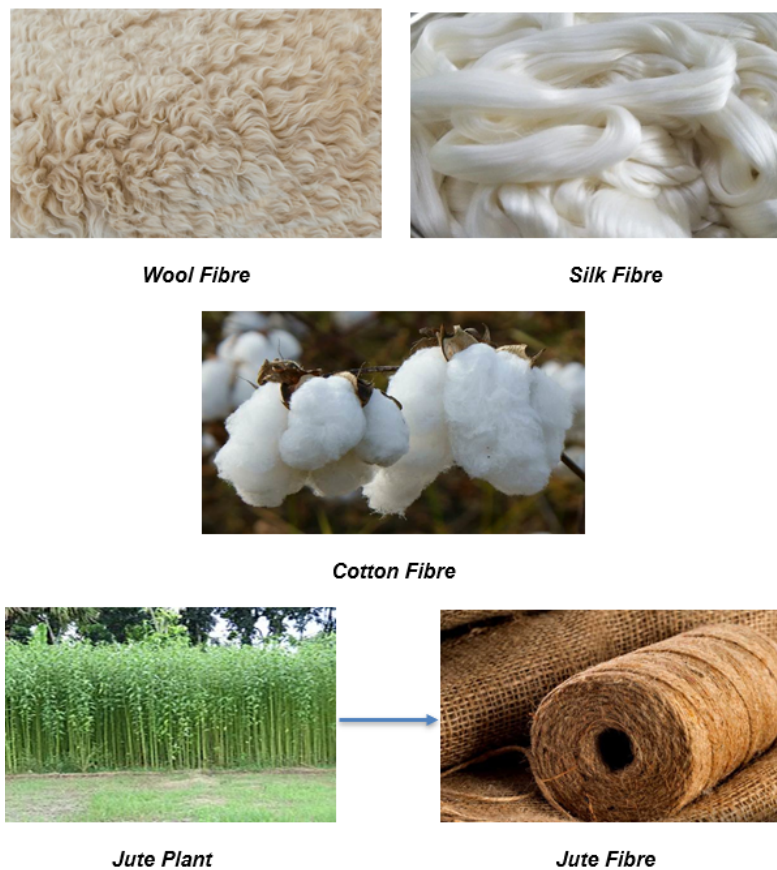

Figure 1. Type of natural fibres commonly used on composites.

The manufacturing industry prefers plant fibres over other fibre types for various uses. To replace synthetic chemicals and non-renewable resources, they are currently a crucial research area for academics around the globe. This is primarily because of their rapid development, low cost, continuous availability, environmental friendliness, and abundance. Natural fibres can be made from a variety of renewable resources, including minerals as well as the plant- and animal-based materials. There are two primary sources of natural fibres: plant and animal-based materials [16].

Wool is the textile fibre obtained from sheep and other mammals, especially goats, rabbits, and camelids. The term may also refer to inorganic materials, such as mineral wool and glass wool, that have properties similar to animal wool. It seems to have been the first fibre spun into yarn and fashioned into fabric. Wool is a member of the keratin protein family, including hair and other forms of protective tissues found in animals,

including horns, nails, feathers, beaks, and outer layers of skin. Wool's relative significance as a textile fibre has decreased over the past few decades as synthetic fibres have become more prevalent in textile products. Silk is also a natural textile fibre which is obtained from silkworms. The rearing of silkworms to obtain silk is known as sericulture. Silk is mainly used for manufacturing clothes. Woven silk fibres are used for the construction of parachutes and bicycle tires [17]. Silk fibres can also be used in thermoplastic matrices as reinforcements to produce composite materials with a high strain to the failure rate. Since silk yarn is commonly accessible as a by-product of the textile industry, silk fibre-reinforced composites are both affordable and environmentally beneficial. An environmentally friendly bio-composite is created by mixing silk fibres with biopolymer matrices, like epoxy resins. Due to their adequate strength and superior deformability, silk fibres can significantly increase impact resistance.

Cotton fibre is one of the plant fibres employed to make clothes too. Under a microscope, a cotton fibre looks like a twisted ribbon or a collapsed and twisted tube. These twists are called convolutions. The convolutions give cotton an uneven fibre surface, increasing inter-fibre friction and enabling fine cotton yarns of adequate strength to be spun. Cotton fibres are natural hollow fibre, a soft staple fibre found as balls around the seeds in a cotton plant. Cotton is used to make soft, breathable, and durable textiles. At the same time, jute is a soft, glossy, coarsely robust thread made from plant fibre. Many agricultural and industrial products must be packaged in bags, sacks, packs, or wrappings using jute fibre. Jute fibres insulate effectively against thermal and acoustic energy with only a slight regain of moisture and no skin irritations [18]. The largest market for jute fibres is in the bag cloth sector. Jute bags have gained popularity as a more environmentally friendly alternative to paper bags, which use much wood in their production, as well as non-biodegradable poly bags derived from petroleum.

Natural fibre such as plant fibre is made of cellulose, hemicellulose and lignin. The anatomy of natural fibre such as sugar palm fibre can be seen in Figure 2. Nurazzi et al. [19] and other researchers [24] discovered that natural fibre has high tensile strength shown in Table 1. Some natural fibres are considered durable with a long-life period as it does not influence by heat and moisture. From this point of view, it can be seen that the natural fibre is a remarkable candidate for reinforcement in polymer matrix composites [20]–[22].

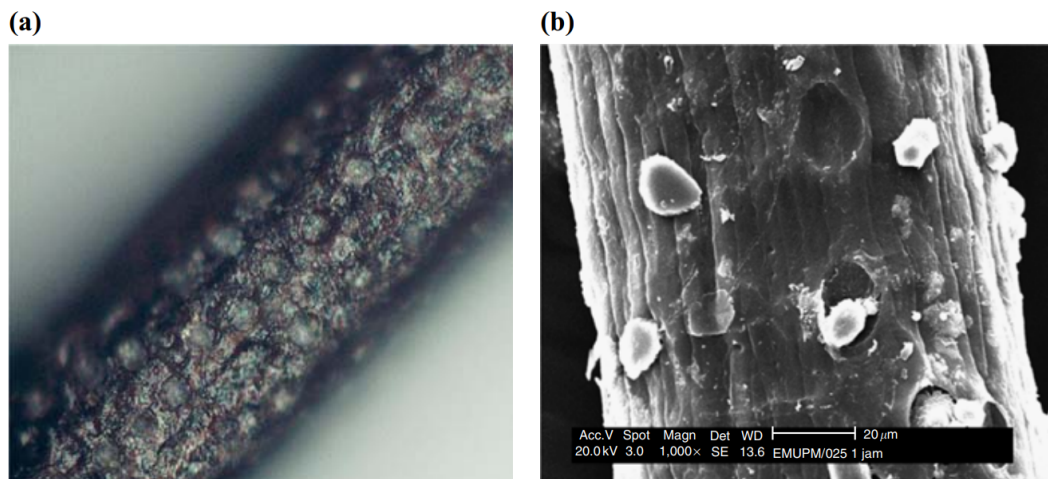

Figure 2. Natural fibre (sugar palm) anatomy in (a) Optical camera; (b) SEM micrograph. Creative Common CC BY license [23]

Table 1. Density and tensile properties of natural fibres. The data is adapted from Ref. [24]. Creative Common CC BY license.

Fibre	Density (g/cm ³)	Elongation at Break (%)	Tensile Strength (MPa)	Tensile Modulus (GPa)
Bagasse	1.5	-	290	17
Bamboo	1.25	-	140 to 230	11 to 17
Coir	1.2	30	138.7	4 to 6
Flax	0.6 to 1.1	2.7 to 3.2	345 to 1035	27.6
Hemp	1.48	1.6 to 4	690	70
Jute	1.3	1.5 to 1.8	393 to 773	26.5
Kenaf	1.45	1.6	215.4	53
Sisal	1.5	2.0 to 2.5	511 to 535	9.4 to 22
Pineapple	0.8 to 1.6	14.5	400 to 627	1.44
Sugar Palm	1.292	7.98	156.96	4.96

3. Synthetic fibres

Synthetic fibres such as nylon, rayon, aramid, glass, and carbon are extensively used for the reinforcement of plastics. Nevertheless, these materials are expensive and are non-renewable resources. Synthetic composites such as glass–polypropylene and glass–epoxies have gaining attention over the last decade. Composites sales in the US rose to 2.8 billion pounds in 2007 from 2.7 billion in 2006. By 2012, it should reach 3.3 billion, growing 3.3% each year [24, 26]. The fibre-reinforced composites market involving carbon and glass fibre composites is now a multibillion-dollar business.

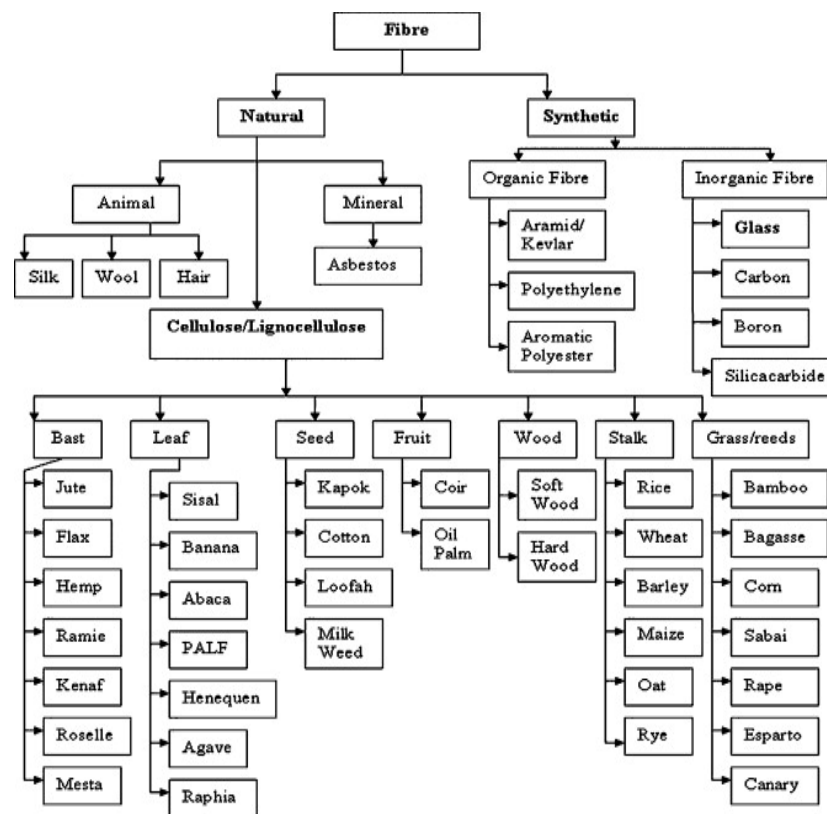

Figure 3. Categories of synthetic and natural fibres [19]

Glass fibre is a versatile material with various properties that make it useful in many applications. One of the critical benefits of glass fibre is its high tensile strength, which is greater than that of steel wire of the same diameter, but at a lower weight. Additionally, glass is known for its dimensional stability, which means it maintains its shape and size even under varying temperature and humidity conditions. Another advantage of glass is its high heat resistance, which allows it to withstand high temperatures without deforming or breaking. Furthermore, glass has good thermal conductivity, which makes it an excellent choice for insulation and heat exchanger applications [25]. Also, glass fibre is known for its excellent fire resistance, making it a safe choice for buildings and other structures. Glass fibre has good chemical resistance, which means it can withstand exposure to various chemicals without deteriorating. Lastly, glass has outstanding electrical properties and dielectric permeability, which makes it useful in electrical and electronic applications. Glass fibre-reinforced polymer, also known as glass fibre-reinforced plastic, is a composite material weaving fibre E-glass fibre and polyester material together. It has a tensile strength of 2000 MPa, and a compressive strength of 140-350 MPa while only weighing a quarter of the weight of steel [26].

Due to their light weight, high specific strength, and high specific stiffness, carbon fibre reinforced polymer (CFRP) composites are used in aerospace, military, wind power, and high-end civil applications [19]. CF reinforces CFRP and polymer bonds and protects fibres. Interface optimisation is the key to closing the gap between CFRP strength and

theoretical calculation. Composite strength and toughness depend on the interface, which transfers and distributes load between matrix and reinforcement [27]. However, CF is a disordered graphite structure with a smooth, chemically inert surface and low surface energy, causing poor resin-CF interfacial performance. Thus, CFRP has limited use.

4. Mechanical Properties of Hybrid Natural/Synthetic Fibre Reinforced Polymer Composites Honeycomb Structure

A sandwich structure consists of a load-distributing core between two skins, or layers, that are themselves stiff and robust. The skins are responsible for the bending and turgidity, while the adhesive transfers the shear and axial stresses to the core material. Light metals make up the skin, which weights a few millimetres. Aluminium, laminated, and fibre-reinforced composites are light alloys. Sandwich constructions utilise honeycomb, lattice, truss, web-reinforced, and cellular cores. The structure's application, lifespan loading, and material value and pricing determine the sandwich materials to utilise. Aerospace uses carbon/epoxy and graphite/epoxy with multiple facings. Glass epoxy or vinyl ester is used for civil, marine, and domestic product facings.

A study of natural fibre composites has reached a point where natural fibre can be used to supplant glass fibre with high specific strength and modulus [27, 28]. Recent research has focused on natural fibre-reinforced polymer composites for sandwich structure applications [29]. The natural fibre composite is utilized in sandwich panel constructions as both the epidermis and interior material. Du et al. [30] studied sandwich panels with paper-reinforced polymer (PRP) composite as the epidermis material and natural fibre incorporated into the structure as the interior. Recent research by Du et al. [31], produced bio-based sandwich-structured composites with bio-fibre and polylactic acid (PLA) matrix epidermis and inner materials. Afterwards, an evaluation of the flexural properties and failure modes of the structures was conducted. Stocchi et al. [32] investigated a novel honeycomb core fabricated by lateral compression molding from a jute-reinforced vinylester composite. In addition, Petrone et al. [33] created an eco-friendly honeycomb core for sandwich panels by combining flax fibre with a polyethylene matrix; their analyses included both reinforced and unreinforced cores. The authors reported that the mechanical properties of reinforced cores (continuous-unidirectional and short-random) were significantly superior to those of unreinforced cores. In addition, the suspension value was improved by filling the interior with wool fibre, resulting in a minimal increase in weight.

In recent years, the hybridization effect of natural fibre composites (NFCs) to enhance their mechanical properties has attracted the attention of researchers [34]. Alavudeen et al. [35] conducted a study on the mechanical properties of hybrid kenaf/banana composites. It was demonstrated that the mechanical properties of kenaf/banana composites were superior to those of individual fibre-based composites. In a similar study

by Venkatesh et al. [36], it was found that the addition of bamboo fibre to sisal-unsaturated polyester composites can improve their mechanical properties, compared to the composites on their own. In addition, Wu et al. [37] hybridized silk fibre and flax fibre and investigated their mechanical properties. The study revealed that the hybrid exhibited superior flexural and impact strength compared to other NFCs. In addition, Gupta et al. [38] investigated the mechanical properties of sisal and banana fibre-reinforced polylactide acid (PLA) composites. According to their research, biocomposites containing treated fibres had superior mechanical properties to those containing PLA or untreated fibres.

In recent times, a few numbers of research are being carried out on hybridization between the natural fibres as a composite with respect to their energy absorption characteristic. For instance, an examination of external basalt layers' influence on the mechanical degradation of flax composites when situated in critical environments [39]. They reported that the addition of an external basalt laminate to a flax composite enhanced the laminate's mechanical integrity under static and dynamic stresses. In contrast to flax-based composites, which were able to increase their energy absorption capacity as they aged, the basalt-flax hybrid was incapable of substantially varying its impact strength. Similarly, Živković et al. [40] analyzed the influence of moisture absorption on the impact properties of dry and conditioned basalt, flax, and hybrid flax/basalt fibre composites. The authors observed significant enhancements in energy absorption for hybrid composites compared to their single composite counterparts, particularly for conditioned samples. Senthil Kumar et al. [41] examined a hybridization of banana and coconut fibres and the effect of their layering pattern. The individual composites and the hybrid were compared, and the results showed that the coconut fibre as the outer layer exhibited the utmost damping behavior and therefore, better energy absorption capability.

5. Current Structural Applications of Hybrid Synthetic and Natural Fibre in honeycomb sandwich structure

5.1 Automotive

The most likely method to meet fuel-efficiency demand with less impact on the environment in the automobile sector is by implementing lightweight materials such as hybrid natural/synthetic fibre honeycomb sandwich composites in automobile parts. A hybrid biocomposite sandwich structure permits high mechanical strength and stiffness due to the polymeric matrix aiding in transferring the load to the fibre and safeguarding the fibre from adverse environments and mechanical damage. It is well known that hybrid natural fibre composites exhibit low density, less cost, and are widely available, as carmakers across continents have used them to produce a variety of automotive components. Table 2 displays automotive manufacturers that utilize natural fibre

composites in their automotive parts. According to Ishak et al. [42], it is estimated that around 16 million cars were manufactured in Western Europe per annum, and around 80,000 to 160,000 tons of natural fibre were used.

For instance, Yusof et al. [43] developed a conceptual design for a hybrid palm oil polymer composite automotive crash box. They combined the Theory of Inventive Problem Solving (TRIZ), morphological charts, and biomimetics to fulfil the material characteristics, function specifications, force identification, root cause analysis and geometry profile. Apart from that, Mansor et al. [44] studied the material selection process for an automotive lever brake using the Analytic Hierarchy Process (AHP). They have chosen kenaf bast fibre to hybridize with glass fibre-reinforced polymer composites to design a parking brake component based on the highest overall scores in AHP. Other than that, Adesina et al. [45] reviewed the mechanical properties of hybrid natural fibre composites for a bumper beam. Lower impact properties were discovered based on the mechanical evaluation of the various research studies using natural fibre as a major limitation compared to the conventional glass fibre composites applied as typical bumper beam material. Thus, hybridization natural with synthetic fibres aid in compensating for the limitation of natural fibres when used in a hybrid to improve the mechanical properties of the polymer composite.

Table 2. Automotive models and their components implementing natural fibre composites [46]

Model	Brands	Components
C3 Picasso, C5	Citroen	Boot linings, mud guards, interior door paneling, parcel shelves, and door panels
Passant Variant, Golf, A4, Bora	Volkswagen	Door panel, boot-liner, seat back and boot-lid finish panel
Vectra, Astra, Zafira	Opel	Head-liner panel, pillar cover panel, door panels and instrumental panel
3,5 and 7 series	BMW	Noise insulation panels, headliner panel, seat back, door panels, molded foot well linings and boot-linings
Mondeo CD 162, Focus	Ford	Floor trays, door inserts, door panels, B-pillars and boot-liner
C70, V70	Volvo	Seat padding, natural foams, cargo floor tray, dash, boards and ceiling
Eco Elise	Lotus	Seats, interior carpets, body panels and spoiler
ES3	Toyota	Pillar garnish and other interior parts
2000	Rover	Rear storage shelf panel and insulations

Another example is the bumper beam (Figure 4) is typically made of a robust and lightweight material such as high-strength material and is designed to absorb and distribute the impact energy of a collision. The bumper beam is located behind the hybrid natural/synthetic fibre honeycomb sandwich composites cover of the bumper and is connected to the frame or chassis of the vehicle. In the event of a collision, the bumper beam helps to protect the car's occupants and other safety-critical systems by absorbing and distributing the impact energy, thereby reducing the likelihood of damage to the car's body and occupants [47]. The bumper beam can also have sensors and other electronic components for ADAS (Advanced Driver Assistance Systems), such as park assist and lane departure warning.

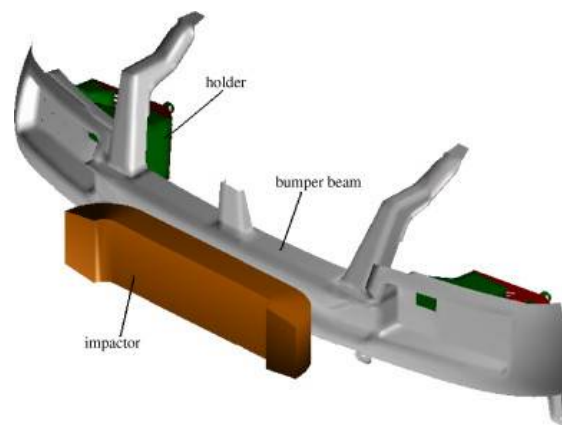

Figure 4. Bumper beam as automotive application [47]

5.2 Aerospace

Aerospace industries and commercial aircraft components have been the highest use of hybrid natural/synthetic fibres sandwich composites. Unlike other land and water vehicles, aircraft require placing greater attention on safety and weight. Currently, hybrid glass/carbon composites are implemented in these vehicle components due to the low raw material cost and high mechanical strengths. For instance, hybrid fibre-reinforced epoxy composites would result in enhanced performance of the aircraft's interior panel. Applying flax fibre in hybrid fibre-reinforced epoxy matrix composites shows that the sound absorption coefficient was about 20% higher than the glass fibre counterpart at both low and high-frequency levels [48]. In addition to this statement, bamboo could be a potential candidate to implement as a sub-constituent in flax/epoxy composites since bamboo/epoxy has 14% and 9% higher tensile and compressive strength, respectively, as compared to flax/epoxy composites. Hence, hybrid flax/synthetic fibre composites demonstrated potential wideband sound absorption and met the interior aircraft panel criteria. Moreover, aircraft radome, which shields radar antennae from weather, aerodynamic loads, and bird strike, has the potential to benefit from hybrid natural fibre composites. In term radio-frequency transparency, glass fibre composites are primarily employed since they allow radio frequency fields can penetrate with no heating occurring. The application of glass fibre composites were also required for aircraft radome due to high-toughness composites with a low dielectric constant. Thus, it is potential natural fibre hybridized with glass fibre composites in aircraft radome usage. Based on the preliminary review of compilation data of natural fibre such as bamboo, banana, kenaf, oil palm, and pineapple leaf (PALF) fibres by Haris et al. [49], hybrid treated kenaf/glass reinforced epoxy composites can be the potential material to be implemented in radome application. Specifically, the standard mould size for generic radome ranges from 15 to 20 inches. It can be fabricated via vacuum bagging or hand lay-up to form a dome-shaped glass/kenaf composite laminate. In general, kenaf fibre displays good overall performance compared to bamboo, banana, oil palm, and PALF.

5.3 Naval

Generally, marine structures such as ships are under constant attack by rust, leading to defects. An outer pressure hull is a submarine's structural component designed to withstand the external water pressure at the depths at which the submarine operates. The hull is made of thick steel plates welded or riveted together to form a watertight barrier. The outer pressure hull encloses the living and working spaces of the submarine, including the control room, crew quarters, and engine room. It also houses the ballast tanks, which control the submarine's buoyancy, and the propulsion system. The hull is designed to maintain its structural integrity and prevent water from entering the submarine in the event of a collision or other external damage. Most ship hulls are made of carbon steel, which is susceptible to corrosion and has different thermal and electromagnetic detection from long range. These issues have brought material scientists and marine engineers to implement lignocellulosic composites, which are greener than conventional steel. In this case, hybrid configurations of natural fibre composites were used by many researchers due to the limited durability of natural fibre composite (NFCs) materials if subjected to physical–chemical attacks [50]. NFCs tend to have a high-water absorption rate, leading to a rapidly decreasing mechanical behaviour since they have weak compatibility between hydrophilic natural fibres and hydrophobic polymer matrices. In this context, hybridising natural fibres with synthetic fibres, producing superior ageing resistance and better thermal and mechanical stability, has recently attracted attention thanks to their advantages in terms of compromise between environmental impact, mechanical performance, cost, and durability. For instance, Calabrese et al. [51] discovered that the flax/glass fibres composite laminate permits improving the bending strength and modulus by 90% and 128%, respectively, even if these properties are lower than those of full glass laminates. The findings demonstrated that combining flax and glass fibre-reinforced polymer composites is a practical approach to boost ageing durability, especially under marine environmental conditions to replace conventional steel. Another research study led by Misri et al. [52] evaluates the mechanical performances of a woven glass/sugar palm fibres-reinforced unsaturated polyester hybrid composite. Thus, it is potential to be used hybrid natural/synthetic fibre reinforced polymer composites sandwich composites in naval parts due to corrosion resistance and outstanding mechanical performance.

6. Conclusions

The mechanical performance of hybrid natural/synthetic fibre sandwich composites has seen various research and development in recent decades. Fibre selection, extraction, handling, interfacial engineering, and composite manufacturing have all advanced. This paper reviewed studies on enhancing the materials' strength, stiffness, impact strength, and long- and short-term performance. Regarding stiffness and cost, natural fibre polymer composites are now competitive with other synthetic polymer composites; tensile and impact strength values are approaching synthetic values. Hybrid natural/synthetic

sandwich composites are also used in various structural and outdoor applications, including vehicle exterior underfloor panelling, aircraft components, recreational equipment, and marine structures. The most common source of crack propagation is composite cracking, caused by the formation of displacement discontinuity surfaces within the composites. Fatigue failure may occur in various structural components below the material's ultimate tensile strength. Fatigue failure is thought to be responsible for half of all structural component failures. Micro-buckling of fibre composite laminates begins at the open hole and spreads outward from the hole's tip. However, several studies have been performed to determine the effect of natural fibre blending at different fibre loadings on mechanical properties. The introduction of hybrid natural/synthetic sandwich composites improved the tensile, flexural and impact properties of hybrid composites due to the increased fibre loading. Hybrid natural/synthetic sandwich composites' tensile and flexural strengths are increased by up to 70% by weight. Morphological analysis of hybrid natural/synthetic sandwich composites showed that strong fibre spreading and interfacial bonding between fibre and matrix enhance their mechanical strength. Thus, more research is needed to broaden their application spectrum, which includes improving moisture resistance and fire retardancy. Additionally, relevant concept details can be created to popularise the use of these new materials. When hybridization is attempted, more research into the effects of natural fibres on ageing is required. Since hybrid natural/synthetic sandwich composites do not provide the expected strength values based on the law of mixtures, comprehensive basic studies on factors related to strength, such as interface bonding and fracture mechanisms, will be conducted to aid the future production of these composites for appropriate applications. Overall, the growth of hybrid composites of natural fibres and polymers is rapid, and their applications seem to have a bright future in the coming years.

Acknowledgments: The authors would like to express their gratitude for the financial support received from Universiti Teknologi Malaysia through the project "Characterizations of Hybrid Kenaf Fibre/Fibreglass Meshes Reinforced Thermoplastic ABS Composites for Future Use in Aircraft Radome Applications" under grant number PY/2022/03758—Q.J130000.3824.31J25.

References

- [1] W. Ashraf, M. R. Ishak, M. Y. M. Zuhri, N. Yidris, A. M. B. Yaacob, and M. R. M. Asyraf, "Investigation of different facesheet materials on compression properties of honeycomb sandwich composite," in *Seminar Enau Kebangsaan*, 2019, pp. 129–132.
- [2] M. R. M. Asyraf, M. R. Ishak, S. M. Sapuan, N. Yidris, and R. A. Ilyas, "Woods and composites cantilever beam: A comprehensive review of experimental and numerical creep methodologies," *J. Mater. Res. Technol.*, vol. 9, no. 3, pp. 6759–6776, 2020.
- [3] M. R. M. Asyraf, M. R. Ishak, M. R. Razman, and M. Chandrasekar, "Fundamentals of creep, testing methods and development of test rig for the full-scale crossarm: A review," *J. Teknol.*, vol. 81, no. 4, 2019.

- [4] M. R. M. Asyraf, M. R. Ishak, S. M. Sapuan, and N. Yidris, "Conceptual design of creep testing rig for full-scale cross arm using TRIZ-Morphological chart-analytic network process technique," *J. Mater. Res. Technol.*, vol. 8, no. 6, pp. 5647–5658, Oct. 2019.
- [5] M. R. M. Asyraf, M. R. Ishak, S. M. Sapuan, and N. Yidris, "Conceptual design of multi-operation outdoor flexural creep test rig using hybrid concurrent engineering approach," *J. Mater. Res. Technol.*, vol. 9, no. 2, pp. 2357–2368, Mar. 2020.
- [6] A. N. Johari *et al.*, "Fabrication and cut-in speed enhancement of savonius vertical axis wind turbine (SVAWT) with hinged blade using fiberglass composites," in *Seminar Enau Kebangsaan*, 2019, pp. 978–983.
- [7] M. R. M. Asyraf *et al.*, "Integration of TRIZ, Morphological Chart and ANP method for development of FRP composite portable fire extinguisher," *Polym. Compos.*, vol. 41, no. 7, pp. 2917–2932, Jul. 2020.
- [8] D. Gay, S. V. Hoa, and S. W. Tsai, *Composite materials: Design and applications*, 3rd ed. Boca Raton, USA: CRC press, 2002.
- [9] V. Birman and G. A. Kardomateas, "Review of current trends in research and applications of sandwich structures," *Compos. Part B Eng.*, vol. 142, pp. 221–240, 2018.
- [10] J. J. Carruthers, A. P. Kettle, and A. M. Robinson, "Energy absorption capability and crashworthiness of composite material structures: A review," *Appl. Mech. Rev.*, vol. 51, no. 10, pp. 635–649, 1998.
- [11] A. A. A. Alghamdi, "Collapsible impact energy absorbers: An overview," *Thin-Walled Struct.*, vol. 39, no. 2, pp. 189–213, 2001.
- [12] P. Qiao, M. Yang, and F. Bobaru, "Impact mechanics and high-energy absorbing materials: Review," *J. Aerosp. Eng.*, vol. 21, no. 4, pp. 235–248, 2008.
- [13] G. B. Chai and S. Zhu, "A review of low-velocity impact on sandwich structures," *Proc. Inst. Mech. Eng. Part L J. Mater. Des. Appl.*, vol. 225, no. 4, pp. 207–230, 2011.
- [14] F. Tarlochan, S. Ramesh, and S. Harpreet, "Advanced composite sandwich structure design for energy absorption applications: Blast protection and crashworthiness," *Compos. Part B Eng.*, vol. 43, no. 5, pp. 2198–2208, 2012.
- [15] M. Z. M. Yusoff, "The Properties of Environmentally- Environmentally Friendly Sandwich Structures," University of Liverpool, 2015.
- [16] S. Das Lala, A. B. Deoghare, and S. Chatterjee, "Effect of reinforcements on polymer matrix bio-composites - An overview," *IEEE J. Sel. Top. Quantum Electron.*, vol. 25, no. 6, pp. 1039–1058, 2018.
- [17] D. U. Shah, D. Porter, and F. Vollrath, "Can silk become an effective reinforcing fibre? A property comparison with flax and glass reinforced composites," *Compos. Sci. Technol.*, vol. 101, pp. 173–183, 2014.
- [18] A. Qaiss, R. Bouhfid, and H. Essabir, "Effect of Processing Conditions on the Mechanical and Morphological Properties of Composites Reinforced by Natural Fibres," in *Manufacturing of Natural Fibre Reinforced Polymer Composites*, M. S. Salit, M. Jawaid, N. B. Yusoff, and M. E. Hoque, Eds. 2015, pp. 177–197.
- [19] N. Mohd Nurazzi, A. Khalina, S. M. Sapuan, A. H. A. M. Dayang Laila, M. Rahmah, and Z. Hanafee, "A review: Fibres, polymer matrices and composites," *Pertanika J. Sci. Technol.*, vol. 25, no. 4, pp. 1085–1102, 2017.
- [20] B. Rashid, Z. Leman, M. Jawaid, M. J. J. Ghazali, and M. R. R. Ishak, "Dynamic Mechanical Analysis of Treated and Untreated," *Bioresources*, vol. 12, pp. 3448–3462, 2017.
- [21] M. N. Norizan, K. Abdan, M. S. Salit, and R. Mohamed, "Physical, mechanical and thermal properties of sugar palm yarn fibre loading on reinforced unsaturated polyester composites," *J. Phys. Sci.*, vol. 28, no. 3, pp. 115–136, 2017.
- [22] M. S. N. Atikah *et al.*, "Degradation and physical properties of sugar palm starch/sugar palm nanofibrillated cellulose bionanocomposite," *Polimery/Polymers*, vol. 64, no. 10, pp. 680–689, 2019.
- [23] D. Bachtiar, S. M. Sapuan, E. S. Zainudin, A. Khalina, and K. Z. M. Dahlan, "The tensile properties of single sugar palm (Arenga pinnata) fibre," *IOP Conf. Ser. Mater. Sci. Eng.*, vol. 11, p. 012012, 2010.
- [24] N. M. Nurazzi *et al.*, "A Review on Mechanical Performance of Hybrid Natural Fiber Polymer Composites for Structural Applications," *Polymers (Basel)*, vol. 13, no. 13, p. 2170, Jun. 2021.

- [25] M. R. M. Asyraf and M. Rafidah, "Mechanical and Thermal Performance of Sugar Palm Fibre Thermoset Polymer Composites: A Short Review," *J. Nat. Fibre Polym. Compos.*, vol. 1, no. 1, p. 2, 2022.
- [26] P. N. B. Reis, M. A. Neto, and A. M. Amaro, "Effect of the extreme conditions on the tensile impact strength of GFRP composites," *Compos. Struct.*, vol. 188, pp. 48–54, 2018.
- [27] M. D. Teli and J. Sheikh, "Modified bamboo rayon–copper nanoparticle composites as antibacterial textiles," *Int. J. Biol. Macromol.*, vol. 61, pp. 302–307, 2013.
- [28] K. L. Pickering, M. G. A. Efendy, and T. M. Le, "A review of recent developments in natural fibre composites and their mechanical performance," *Compos. Part A Appl. Sci. Manuf.*, vol. 83, pp. 98–112, 2016.
- [29] M. R. M. Asyraf *et al.*, "Creep test rig for full-scale composite crossarm: Simulation modelling and analysis," in *Seminar Enau Kebangsaan*, 2019, pp. 34–38.
- [30] Y. Du, N. Yan, and M. T. Kortschot, "Light-weight honeycomb core sandwich panels containing biofiber-reinforced thermoset polymer composite skins: Fabrication and evaluation," *Compos. Part B Eng.*, vol. 43, no. 7, pp. 2875–2882, 2012.
- [31] Y. Du, N. Yan, and M. T. Kortschot, "Novel lightweight sandwich-structured bio-fiber-reinforced poly(lactic acid) composites," *J. Mater. Sci.*, vol. 49, no. 5, pp. 2018–2026, Mar. 2014.
- [32] A. Stocchi, L. Colabella, A. Cisilino, and V. Álvarez, "Manufacturing and testing of a sandwich panel honeycomb core reinforced with natural-fiber fabrics," *Mater. Des.*, vol. 55, pp. 394–403, 2014.
- [33] G. Petrone, S. Rao, S. De Rosa, B. R. Mace, F. Franco, and D. Bhattacharyya, "Behaviour of fibre-reinforced honeycomb core under low velocity impact loading," *Compos. Struct.*, vol. 100, pp. 356–362, 2013.
- [34] F. E. Sezgin, M. Tanoğlu, O. Ö. Eğilmez, and C. Dönmez, "Mechanical behavior of polypropylene-based honeycomb-core composite sandwich structures," *J. Reinf. Plast. Compos.*, vol. 29, no. 10, pp. 1569–1579, 2010.
- [35] A. Alavudeen, N. Rajini, S. Karthikeyan, M. Thiruchitrabalam, and N. Venkateshwaren, "Mechanical properties of banana/kenaf fiber-reinforced hybrid polyester composites: Effect of woven fabric and random orientation," *Mater. Des.*, vol. 66, no. PA, pp. 246–257, 2015.
- [36] R. P. Venkatesh, K. Ramanathan, and S. R. Krishnan, "Study on physical and mechanical properties of NFRP hybrid composites," *Indian J. Pure Appl. Phys.*, vol. 53, no. 3, pp. 175–180, 2015.
- [37] C. Wu, K. Yang, Y. Gu, J. Xu, R. O. Ritchie, and J. Guan, "Mechanical properties and impact performance of silk-epoxy resin composites modulated by flax fibres," *Compos. Part A Appl. Sci. Manuf.*, vol. 117, pp. 357–368, 2019.
- [38] M. K. Gupta, "Effect of frequencies on dynamic mechanical properties of hybrid jute/sisal fibre reinforced epoxy composite," *Adv. Mater. Process. Technol.*, vol. 3, no. 4, pp. 651–664, 2017.
- [39] V. Fiore, T. Scalici, L. Calabrese, A. Valenza, and E. Proverbio, "Effect of external basalt layers on durability behaviour of flax reinforced composites," *Compos. Part B Eng.*, vol. 84, pp. 258–265, 2016.
- [40] I. Živković, C. Fragassa, A. Pavlović, and T. Brugo, "Influence of moisture absorption on the impact properties of flax, basalt and hybrid flax/basalt fiber reinforced green composites," *Compos. Part B Eng.*, vol. 111, pp. 148–164, 2017.
- [41] K. Senthil Kumar, I. Siva, N. Rajini, J. T. Winowlin Jappes, and S. C. Amico, "Layering pattern effects on vibrational behavior of coconut sheath/banana fiber hybrid composites," *Mater. Des.*, vol. 90, pp. 795–803, 2016.
- [42] M. R. Ishak, M. R. M. Asyraf, A. L. Amir, S. M. Sapuan, and N. Yidris, "Potential health risks and precautions during biocomposites product preparations," *INTROPica*, no. 19, pp. 22–24, 2020.
- [43] N. S. B. Yusof, S. M. Sapuan, M. T. H. Sultan, and M. Jawaid, "Conceptual design of oil palm fibre reinforced polymer hybrid composite automotive crash box using integrated approach," *J. Cent. South Univ.*, vol. 27, no. 1, pp. 64–75, 2020.
- [44] M. R. Mansor, S. M. Sapuan, E. S. Zainudin, and A. A. Nuraini, "Conceptual design of kenaf fiber polymer composite automotive parking brake lever using integrated TRIZ-Morphological Chart-Analytic Hierarchy Process method," *Mater. Des.*, vol. 54, pp. 473–482, 2014.

-
- [45] O. T. Adesina, T. Jamiru, E. R. Sadiku, O. F. Ogunbiyi, and L. W. Beneke, "Mechanical evaluation of hybrid natural fibre-reinforced polymeric composites for automotive bumper beam: a review," *Int. J. Adv. Manuf. Technol.*, vol. 103, no. 5–8, pp. 1781–1797, 2019.
- [46] R. A. Ilyas *et al.*, "Macro to nanoscale natural fiber composites for automotive components: Research, development, and application," in *Biocomposite and Synthetic Composites for Automotive Applications*, M. S. Sapuan and R. A. Ilyas, Eds. Amsterdam, Netherland: Woodhead Publishing Series, 2020.
- [47] U. K. Vaidya, F. Samalot, S. Pillay, G. M. Janowski, G. Husman, and K. Gleich, "Design and Manufacture of Woven Reinforced Glass/Polypropylene Composites for Mass Transit Floor Structure," *J. Compos. Mater.*, vol. 38, no. 21, pp. 1949–1971, Nov. 2004.
- [48] J. Zhu, H. Zhu, J. Njuguna, and H. Abhyankar, "Recent development of flax fibres and their reinforced composites based on different polymeric matrices," *Materials (Basel)*, vol. 6, no. 11, pp. 5171–5198, 2013.
- [49] M. Y. Haris, D. Laila, E. S. Zainudin, F. Mustapha, R. Zahari, and Z. Halim, "Preliminary review of biocomposites materials for aircraft radome application," *Key Eng. Mater.*, vol. 471–472, pp. 563–567, 2011.
- [50] S. H. K. Bahrain *et al.*, "Morphological, Physical, and Mechanical Properties of Sugar-Palm (*Arenga pinnata* (Wurmb) Merr.)-Reinforced Silicone Rubber Biocomposites," *Materials (Basel)*, vol. 15, no. 12, p. 4062, Jun. 2022.
- [51] L. Calabrese, V. Fiore, T. Scalici, and A. Valenza, "Experimental assessment of the improved properties during aging of flax/glass hybrid composite laminates for marine applications," *J. Appl. Polym. Sci.*, vol. 136, no. 14, 2019.
- [52] S. Misri, Z. Leman, S. M. Sapuan, and M. R. Ishak, "Mechanical properties and fabrication of small boat using woven glass/sugar palm fibres reinforced unsaturated polyester hybrid composite," *IOP Conf. Ser. Mater. Sci. Eng.*, vol. 11, p. 012015, 2010.